

LAVATORY SUPPORTS WITH CONCEALED ARMS

FLOOR MOUNTED WITH RECTANGULAR 1(25) X 3(76) "PRO-SET" UPRIGHTS

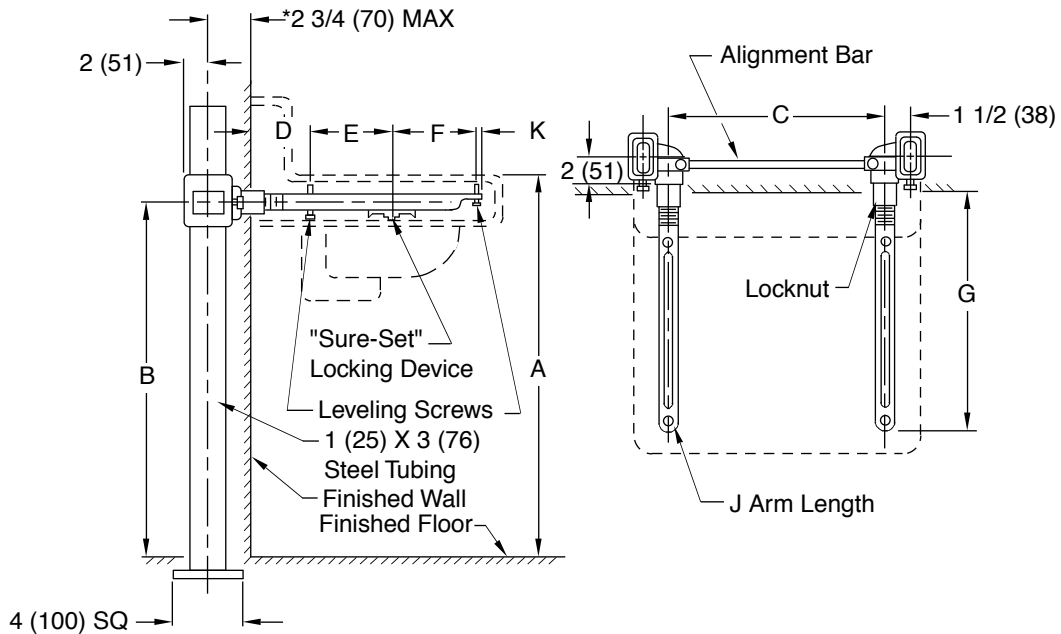
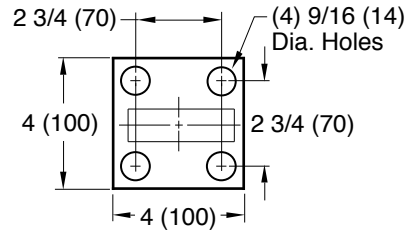

Fig. 0700 (-M31) . . . FOR HIGH BACK LAVATORIES (shown)

NOTE: The rough-in dimensions listed on this drawing are based on current information available to Jay R. Smith by the fixture manufacturers. We recommend that you verify these dimensions with the fixture manufacturer. We will not accept responsibility for rough-in dimension changes by the fixture manufacturer.

NOTE: Dimensions shown in parentheses are in millimeters.

NOTE: Front leveling screws should protrude 1"(25) above arms.



BASE DETAIL

ROUGHING-IN TABLE

| FIXTURE NAME | | | | NUMBER | | | SIZE | |
|--------------|---|---|---|--------|---|---|------|---|
| A | B | C | D | E | F | G | J | K |
| | | | | | | | | |

*This dimension includes wall thickness of 1/2" (13). For greater wall thickness, specify centerline of upright to finished wall dimension.

0700 (-M31)

DIMENSIONS ARE SUBJECT TO MANUFACTURERS TOLERANCE AND CHANGE WITHOUT NOTICE

| | | | | | | | |
|------|----------|--------------------|-----|---------|--------|------------|--------------------|
| H | 10/25/10 | Revised Base Plate | JJ | CL | WEIGHT | VOLUME | FIGURE NUMBER |
| G | 01/08/08 | Revised Base Plate | JJ | BS | POUNDS | CUBIC FEET | 0700 (-M31) |
| F | 1-31-97 | Added dimensions | CMD | BS | | | |
| E | 6-12-95 | Added Millimeters | EMB | BS | | | |
| REV. | DATE | DESCRIPTION | BY | CKD. BY | | | |