

APPLICATION:

PRODUCT NAME:  
WALL BRACKET

JOB NAME:

SPECIAL CONFIGURATION  
 CHECK BASE MODEL AND OPTIONS

QUANTITY:

ITEM NO.

MODEL:  
 2902-12

OPTIONS OR MODIFICATIONS:  
 OTHER \_\_\_\_\_

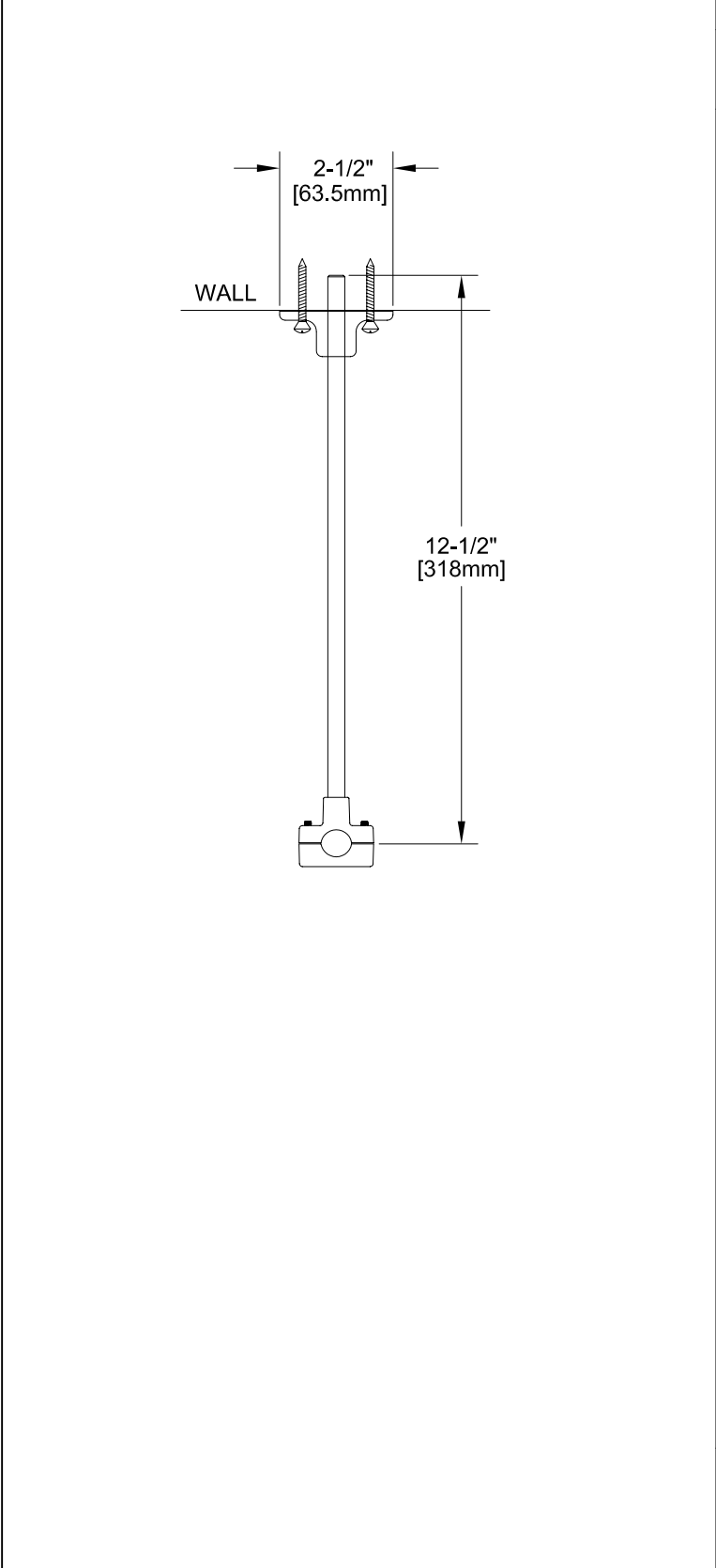

FEATURES

WALL BRACKET  
\* ADJUSTS FROM 2" TO 12"

SHIPPING WEIGHT  
\* 1.0 LB

 ANSI/A112.18.1M

**FISHER**  
 FISHER MANUFACTURING COMPANY  
 TOLL FREE: 800-421-6162 - FAX: 800-832-8238  
 information@fisher-mfg.com - www.fisher-mfg.com