

# Little GIANT®

## 5-ASP-FS SERIES



### Features

- Automatic operation
- Epoxy coated die-cast aluminum housing
- Oil-filled motor
- 26.3' maximum lift
- 380 watts
- 1" FNPT discharge
- Thermal overload protection
- On level: 11"
- Off level: 3"
- Integral float switch
- For submersible use only

### Construction

- Motor — 1/6 HP oil filled
- Intermittent Liquid Temp. up to — 120°F
- Intake — Screened
- Discharge — 1" FNPT
- Housing — Epoxy coated cast aluminum
- Cover — Epoxy coated cast aluminum
- Volute — Nylon
- Impeller — Nylon
- Shaft Seal — Viton®
- Screen — Nylon

Automatic submersible utility pump with oil-filled motor and epoxy coated cast aluminum housing. For commercial, industrial and home applications where liquid must be transferred or recirculated. Pumps down to 1/8". This 1200 GPH pump features a 1" FNPT discharge with garden hose adaptor, 26.3' shut-off head capability, and screened inlet.

# 5-ASP-FS SERIES

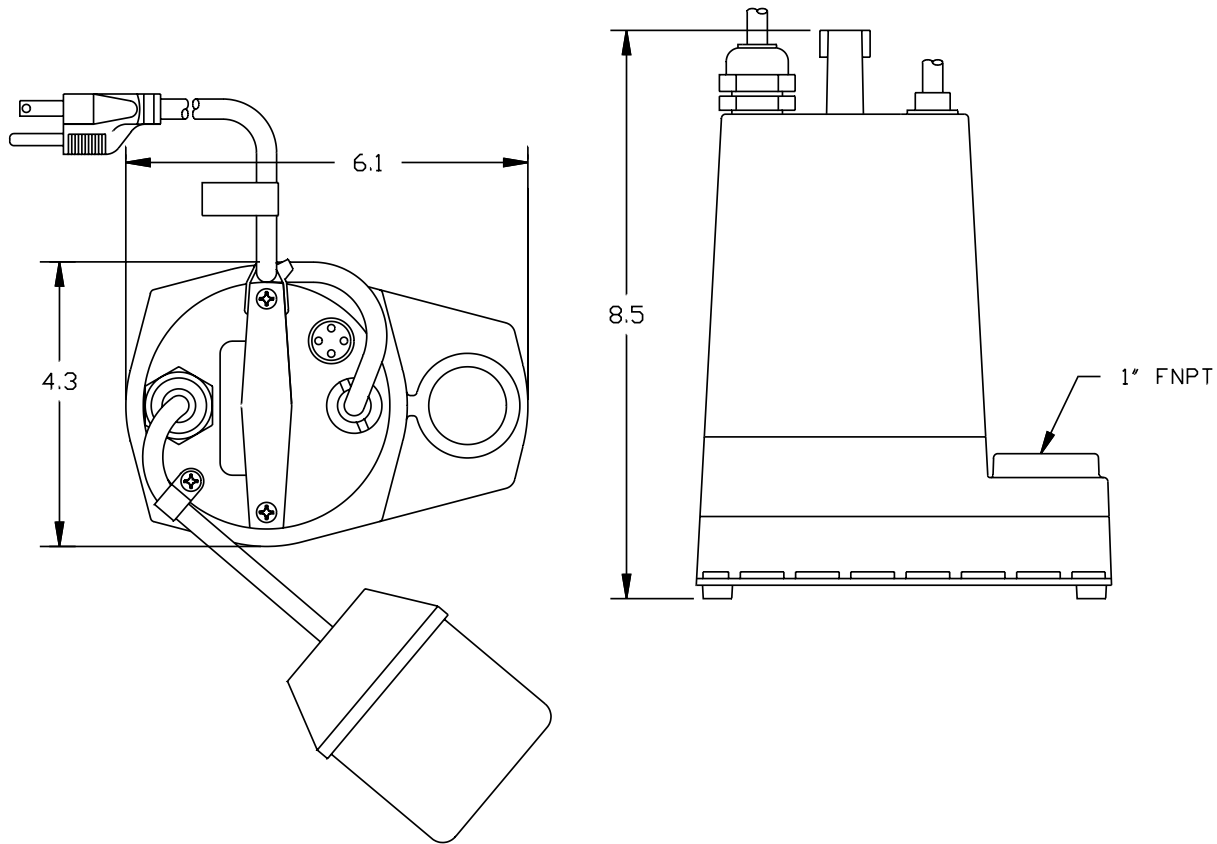

## Specifications

Model No.	Item No.	Discharge Size	Intake	Listing(s)	HP	Volts	Hertz	Amps	Watts	Performance (GPH@Head)					Shutoff		Cord Length (ft.)	Weight (lbs.)
										1'	3'	5'	10'	20'	Ft.	P.S.I.		
5-ASP-FS	505400	1" FNPT	Screened	UL/CSA	1/6	115	60	5.0	380	1200	1170	1100	1000	520	26.3	11.4	10	9.00

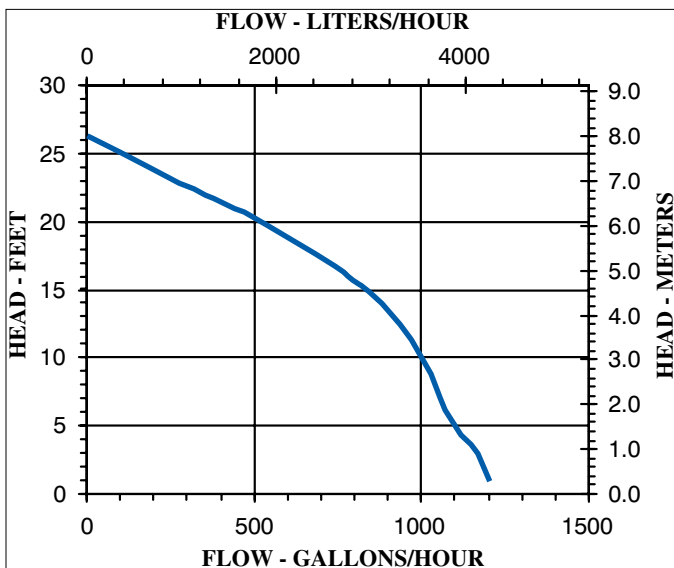

## Replacement Parts

Volute	105200
Screen	105900
Impeller	105310
Handle	105911
Adapter (GH)	599030
Seal Ring	928024